

No. 6919-2

Pallet Decoupler Block

for single acting cylinders,
max. operating pressure 400 bar.

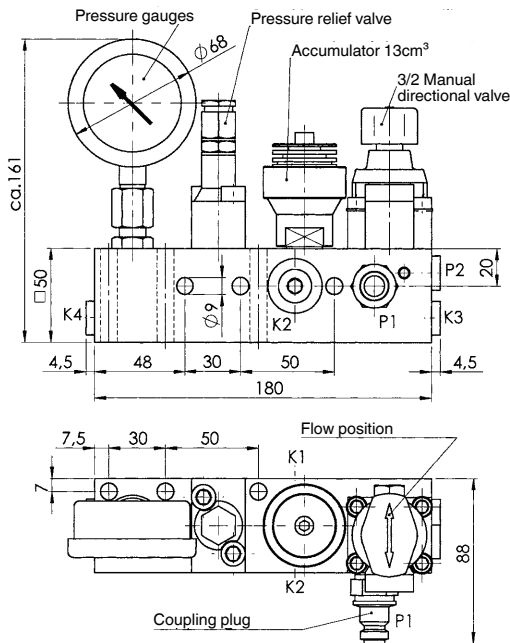

Wiring diagram symbols:

- = Pressure gauges, Order no. 161414
- SP = Accumulator, Order no. 67645
- DBV = Pressure relief valve, Order no. 181222
- V = 3/2 Manual directional valve, Order no. 114298
- K1-K4 = Pressure outputs (Threaded plug), Order no. 69419
- P1 = Pressure input (Coupling plug), Order no. 69039
- P2 = Pressure input (Threaded plug), Order no. 69419
- T = Release opening DBV

Wiring diagram:

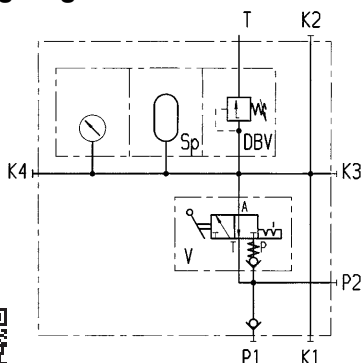

Order no.	Article no.	Set gas preload p0 [bar]	Reservoir volume [cm³]	NG	Q max. [l/min]	Connections inputs P1+P2	Connections outputs K1 to K4	Weight [g]
61168	6919-2	80*	13	4	7,5	G1/4	G1/4	4400

* Adjustable between 20 and 250 bar at works (on request).

Design:

- Distributor made of phosphatized steel
- 3/2-way manual seat valve
- Accumulator
- Pressure-relief valve set to 400 bar
- Pressure gauge (600 bar; nom. size 63; with glycerin damping)
- Coupling connector No. 6990 G1/4 S and fittings

Application:

The main application for the pallet decoupler block is to maintain pressure at fixtures which are disconnected from the pump unit during the machining process. For example on flexible machining centers with pallet changing systems. With tight hydraulic elements a loss in pressure shall be limited to 2 bar/h (see diagram). The integrated accumulator can compensate for a leakage-oil quantity of approx. 6 cm³ in the range from 150 to 400 bar. The pressure input is connected to P1 or P2 and observed by the pressure gauge.

1. Couple pump unit with pallet decoupler block.
2. Switch manual seat valve to flow.
3. Remove workpiece or insert a new.
4. Operate pump unit (clamp).
5. Once pressure has been built up (check at pressure gauge), the seat valve must be set to close.
6. Operate pump unit (unclamp).
7. The pump unit is uncoupled from the pallet decoupler block.

Features:

After disconnecting the pump unit the clamping fixture cannot be depressurized even by operating the seat valve. Compact design. Load outputs (K1 to K4).

Note:

1. If the seat valve is opened in the uncoupled condition, it cannot be coupled again. The seat valve must then be switched to close. Loosen the coupling connector SW (AF) to depressurize 22 and then tighten again.
2. The clamping point can also have pressure applied when the seat valve is set to close.

Diagram:

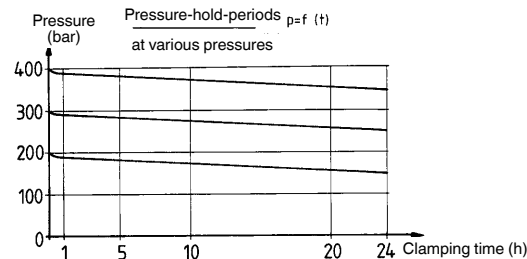

Subject to technical alterations.