

No. 6370HARH

Horizontal rapid-clamping cylinder

Hydraulic opening.
Opening operating pressure: min. 50 bar - max. 60 bar.
Cover and piston hardened.
Repeatability < 0.005 mm.

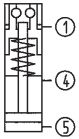
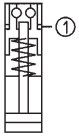

Order no.	Size	Pull-in/locking force up to [kN]	Holding force* [kN]	Advance motion, hydr. suspension piston	max. weight per suspension piston [kN]	Weight [Kg]
303065	K20	20	55	-	5	2,1
306217	K20	20	55	●	5	2,1
303107	K40	40	105	-	8	5,2
306258	K40	40	105	●	8	5,2

Design:

As standard, there is a manual (hand power) or hydraulic run-out and run-in movements of the suspension piston.

- Cylinder has one connection: 1x hydr. opening (1),
- Cylinder with hydraulic advance motion has three connections: 1x hydr. opening (1), Run out 1x hydr. suspension piston opening (5), run in 1x hydr. suspension piston opening (4).

Application:

Zero-point clamping system for set-up-time-optimised clamping during cutting and non-cutting machining. For installation in clamping profiles, cubes and towers. The horizontal toggle clamp cylinder is used to change fixtures quickly and easily by means of the suspension piston with hand force, hydraulic or handling device.

Note:

The horizontal rapid-clamping cylinder has high holding, pull-in and locking forces. This is opened hydraulically (1) and mechanically locked through spring force. Subsequent uncoupling of the pressure lines is possible at all times (module is tensioned pressure-free). The maximum weight per suspension piston must not exceed 5 kN at K20 and 8 kN at K40.

* Please observe the installation instructions.

On request:

- Installation diagrams

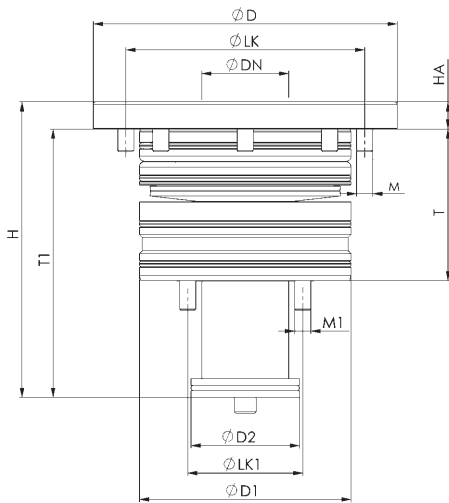

Dimensions:

Order no.	Size	dia. D	dia. DN	dia. D1	dia. D2	H	HA	dia. LK	dia. LK1	M	M1	T	T1
303065	K20	112	32	78	40	109	10	88	60	M6	M6	56,5	99
306217	K20	112	32	78	40	109	10	88	60	M6	M6	56,5	99
303107	K40	148	40	102	48	144	15	118	76	M8	M8	73,0	129
306258	K40	148	40	102	48	144	15	118	76	M8	M8	73,0	129



No. 6370ZMSH

Mounting key for horizontal rapid-clamping cylinder

Suitable for 6370HARH.



Order no.	Size	Weight [g]
424556	K20	520
426866	K40	940

Application:

The mounting key is needed for installation of the threaded sleeve of the horizontal rapid-clamping cylinder.